

# **Kurt J. Lesker** **Company**

1925 Worthington Ave  
Clairton Pa, 15025  
Telephone: (800) 245-1656  
Fax: (412) 384-2745

---

## **EJAT10 AUTOMATIC MATCHING NETWORK OPERATOR'S MANUAL**

Revision 1.02

Document Number 6200090000  
Generic Configuration, 13.56MHz

## **Introduction**

Thank you for acquiring your new KJLC EJAT-Series Automatic Matching Network. All AT Series Matching Networks have been designed to provide the best value, ease of operation, and reliability for plasma and non-plasma processing systems. This manual covers specifications, installation, and operation of the EJAT10 Automatic Matching Network.

This manual assumes the EJAT10 Automatic Matching Network is being used with a plasma processing system. The EJAT10 Automatic Matching Network can also be used in non-plasma processing applications. Consult a KJLC sales or service representative for assistance with non-plasma processing applications.

## **Information**

For technical questions, application assistance, or additional information, contact our customer service department or nearest customer service representative.

## **Service**

Customer Service Representatives are available to answer your technical questions. Should your KJLC product require service, contact the nearest KJLC service representative for a Return Materials Authorization Number. Any returned equipment should be sent freight prepaid.

Please note: Equipment returned to us without prior authorization or without a Return Materials Authorization (RMA) number visible on the outside of the package will be refused.

## **How to Contact Us**

Our address, telephone, and fax numbers are listed below. Office hours are Monday through Friday, 8:00am to 8:00pm, United States Eastern Time

Kurt J. Lesker Company  
1925 Worthington Ave.  
Clairton Pa, 15025

Telephone: 800-245-1656  
Fax: 412-384-2745

## **Proprietary Information Notice**

This document contains information proprietary to KJLC. This document shall not be reproduced or its contents disclosed without the written permission of KJLC. This notice shall appear in all copies.

**TABLE OF CONTENTS**

Safety Notes .....	3
EJAT10 Matching Network Features .....	5
Physical Dimensions .....	6
Controls and Connections .....	8
Unpacking .....	12
Installation .....	12
Operational Checks .....	15
Technical Data .....	16
Ratings and Specifications .....	16
Theory of Operation .....	17
Chassis Schematic .....	19
Typical System Configuration .....	20
Control Interface Connections .....	21
Maintenance .....	22
Problem Solving .....	23
Range Configuration .....	26
Phase and Magnitude Sensor Adjustment Procedure .....	27
Related Documents .....	28
Revision History .....	28
KJLC 1 Year Limited Warranty .....	29
Obtaining Service For The EJAT10 Automatic Matching Network .....	29
Glossary Of Terms .....	30

## Safety Notes

Your AT Series Automatic matching Network has been designed and tested to meet strict safety requirements. These include independent lab examination and approval, and compliance to established standards. Please read the following instructions carefully before operating the Matching Network and refer to them as needed to ensure the continued safe operation of your AT Series Matching Network.

**Follow** all warnings and instructions marked on or supplied with the product.

### Symbology:

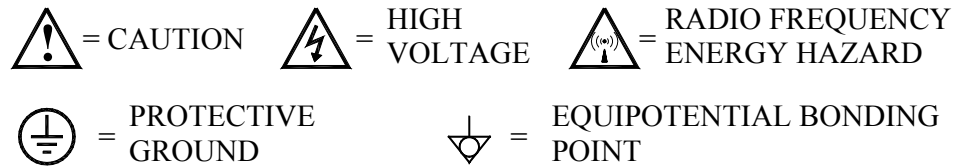

**Unplug** or disconnect this equipment from the Radio Frequency (RF) power source before removal of any covers.

**Do not** use this equipment near wet locations, or outdoors.

**Do not** place this equipment on an unstable cart, stand, or table. The AT Series Matching Network may fall, causing personal injury or damage to the Matching Network. Improper grounding of the Matching Network to the system can result in electrical shock.

**To avoid electric shock**, this unit must be connected in compliance with the National Electrical Code ANSI C1 and/or any other codes applicable to the user. Improper installation may result in a shock or fire hazard.

**It is the responsibility** of the installer to provide a proper protective ground from the Matching Network to the system. The system should be grounded in accordance with local and national electrical codes, and any other codes applicable to the user.

**The AT Series Matching Network Controller (EJMC2)** should be operated from the type of power source indicated on the marking label. If you are not sure of the type of power available, consult an electrician or your local power company.

**Do not** allow anything to rest on the interconnecting cables. Do not locate the AT Series Matching Network where persons will step on the interconnecting cables.

**Never** spill liquid of any kind on or into the Matching Network.

**Never** remove covers or guards that require a tool for removal. This should be performed by a qualified service engineer at the initial matching network set-up configuration for your specific plasma impedance. There are no operator serviceable areas within these covers. Refer servicing to qualified service personnel.

**Never** push objects of any kind into the slots and openings of the Matching Network Controller's enclosure. They may touch dangerous voltage points or short out parts, which could result in a fire or electric shock.

**This product** is to be operated only when all covers are installed, appropriate RF Connections have been made, and all RF Cables are in place and tightened. **DO NOT** operate this unit without connecting the output with the appropriate output cable or strap connected to the plasma reactor.

**HAZARDOUS VOLTAGE PRESENT WITHIN THE UNIT AND AT THE RF OUTPUT CONNECTOR – RISK OF ELECTRICAL SHOCK AND RADIO FREQUENCY ENERGY BURN.**



**CAUTION!**



**ELECTRICAL SHOCK AND RF VOLTAGE  
HAZARD PRESENT INSIDE UNIT AND AT RF  
OUTPUT CONNECTOR.  
DO NOT REMOVE COVERS.  
REFER SERVICING TO QUALIFIED SERVICE  
PERSONNEL.**

## **EJAT10 Automatic Matching Network Features**

The EJAT10 Automatic Matching network is designed for use in conjunction with a KJLC model EJMC2 Matching Network Controller as a component in an RF power delivery system for plasma or other processing applications.

The EJMC2 Matching Network Controller, interconnect cable, and other accessories are sold separately.

The EJAT10 Automatic Matching Network consists of two variable capacitors and a single fixed inductor. The matching network circuit topology is an "L" type. The type "L" circuit configuration provides a wide tuning range and low insertion loss, delivering maximum power transfer to the Plasma Load. The variable capacitors within the EJAT10 Automatic Matching Network are driven by servo-motors, powered by the KJLC model EJMC2 controller.

In the manual mode of operation, the variable capacitors can be positioned using the MIN/MAX switches on the front panel of the EJMC2 controller, controlling the direction of servo-motor rotation, allowing the operator to manually tune the network to match the plasma impedance.

In the automatic mode of operation, the EJAT10 Matching Network's internal sensor, called the Phase and Magnitude detector, generates an error signal. The EJMC2 Matching Network Controller reacts to the error signal and drives the servo-motors, automatically tuning the network to the appropriate plasma impedance.

### Standard EJAT10 Matching Network Features:

- Wide tuning range, custom tuning ranges available
- Generic Application, Sputter Application, or custom configurations available.
- Low loss type "L" circuit topology
- Compact Size
- 1000 Watt nominal input power
- Internal DC Voltage probe with selectable polarity
- Optional RF Voltage probe with selectable polarity available
- Internal Phase and Magnitude error sensor
- Convection Cooled
- Custom output configurations available
- Load and Tune Capacitors are Vacuum Variable types
- Single cable interface to matching network controller

**PHYSICAL DIMENSIONS**

Dimensions in Inch [mm]

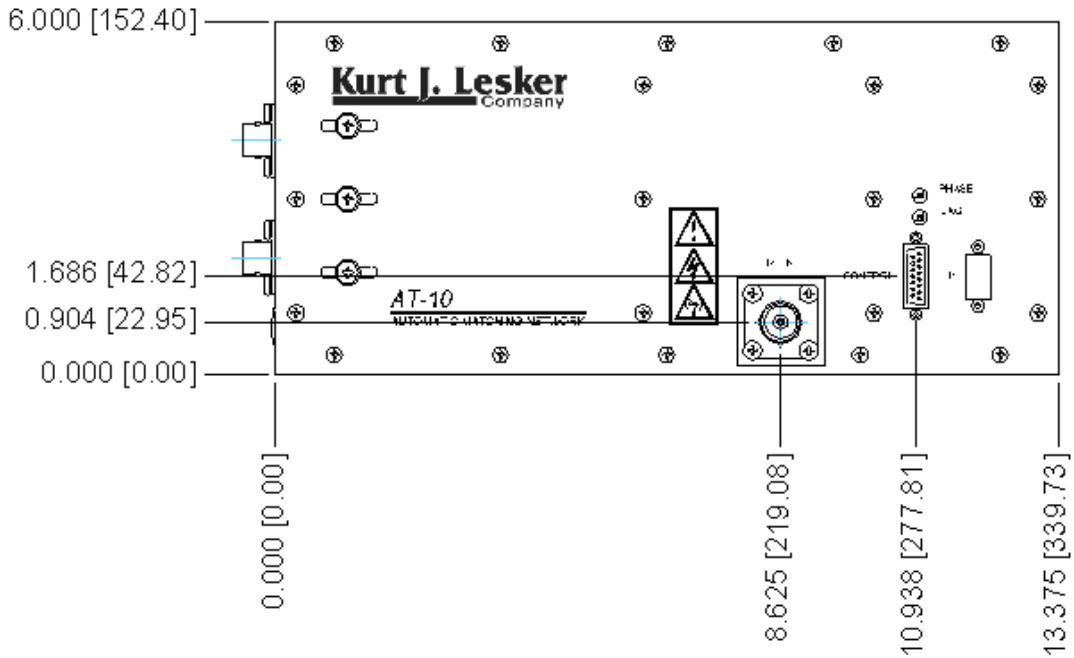

EJAT10 Side View

EJAT10 Rear View

Physical Dimensions

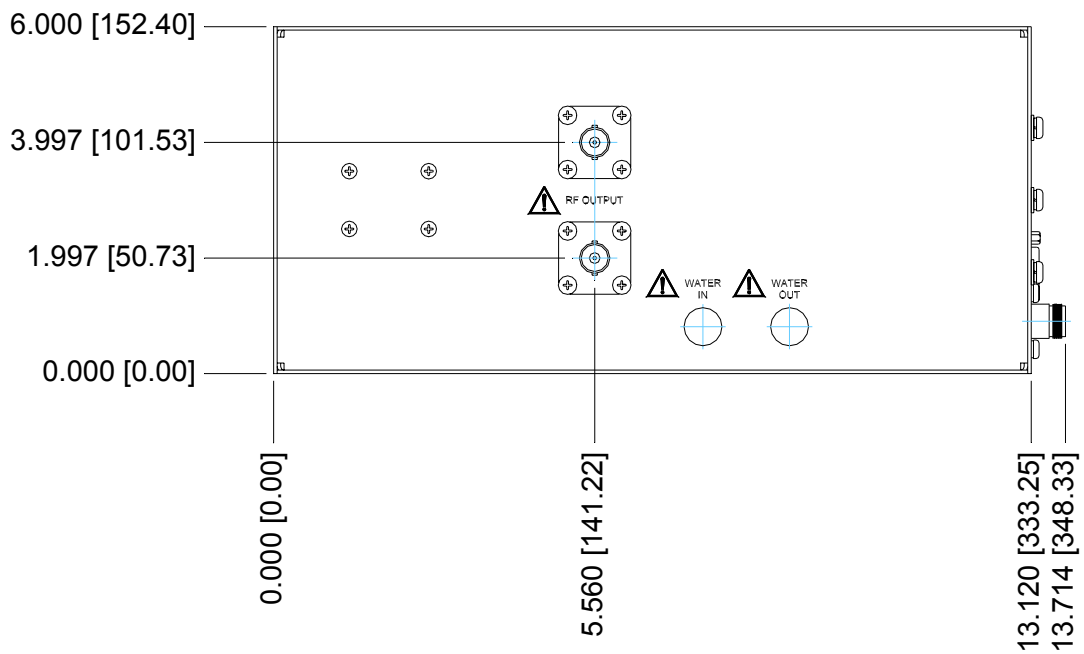

EJAT10 AUTOMATIC MATCHING NETWORK OPERATOR'S MANUAL

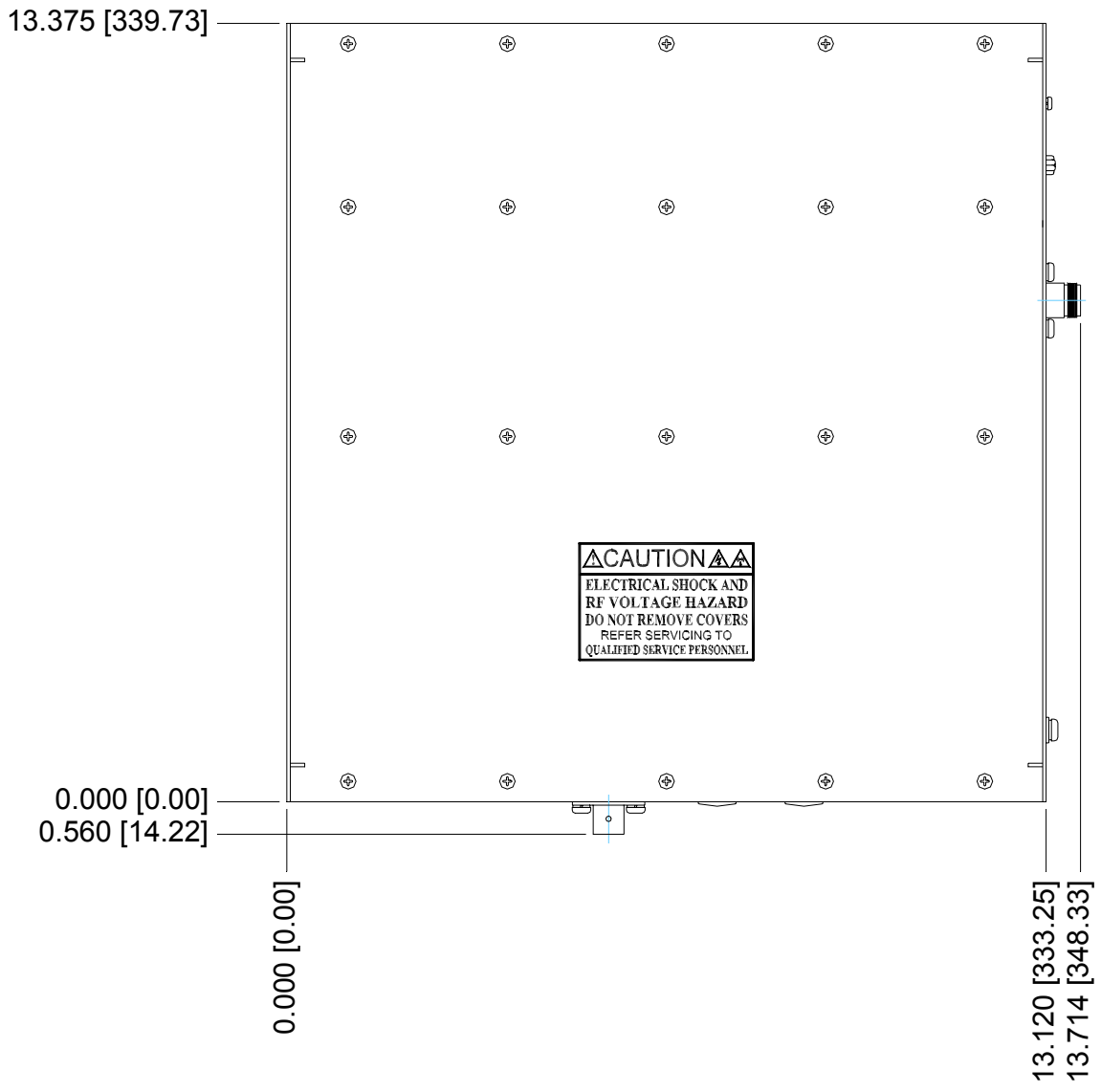

EJAT10 Top View



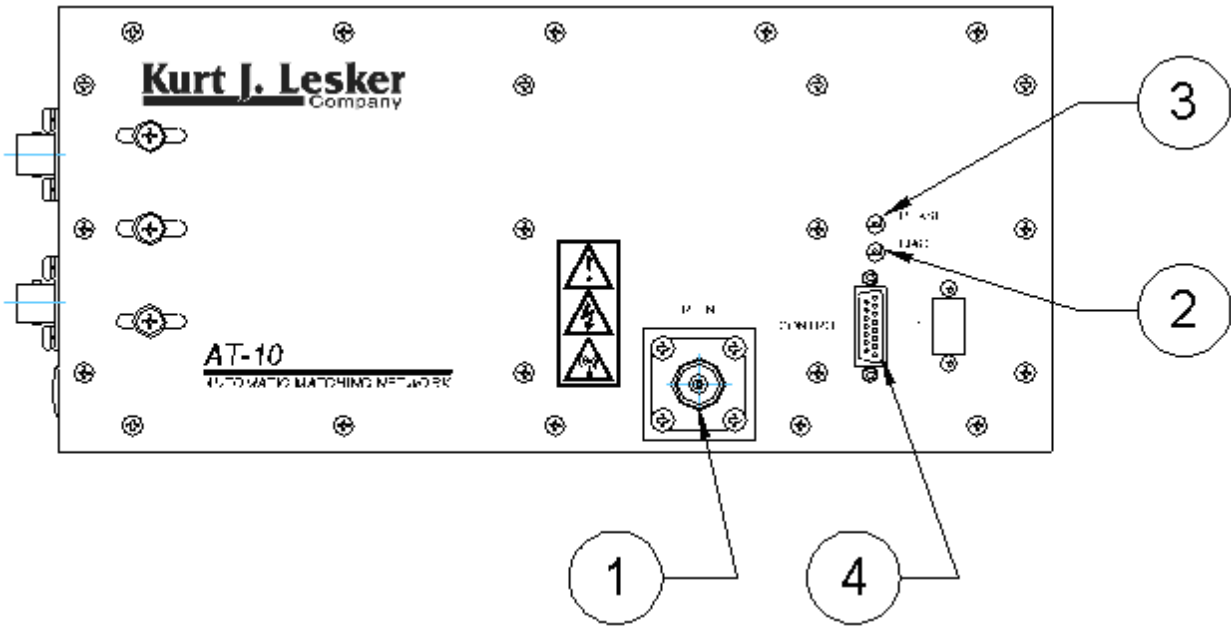

**CONTROLS and CONNECTIONS:**

The EJAT10 Automatic Matching Network has no operator controls. Consult the EJMC2 Matching Network Controller operator’s manual for detailed instructions on automatic and manual control modes, preset operation, and remote control of the EJAT10 Automatic Matching network via the EJMC2 Controller.

EJAT10 Side View

Item	Description
1	RF Input Connector – Type “N” female
2	MAGnitude Sensor Null Adjustment
3	PHASE Sensor Null Adjustment
4	Control Connector - 15 pin female D-Subminiature type

**EJAT10 AUTOMATIC MATCHING NETWORK OPERATOR'S MANUAL**

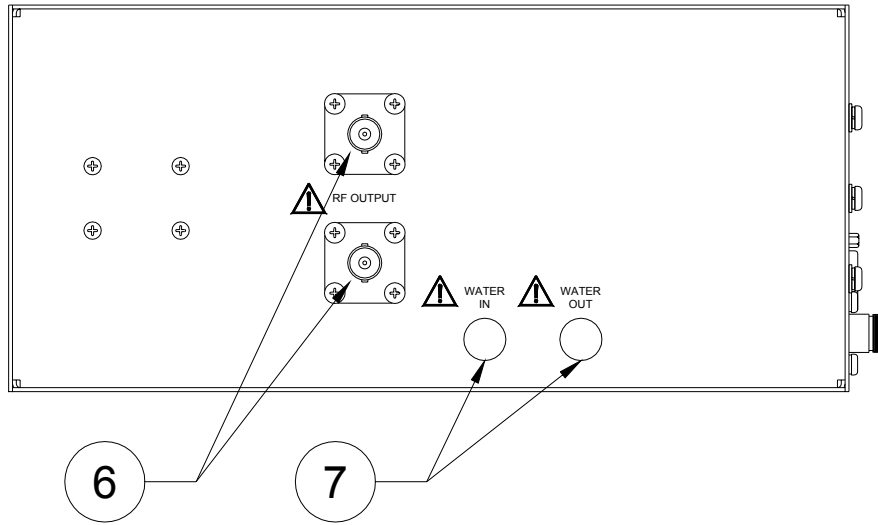

EJAT10 Rear Panel, With Dual “C” Output Connectors

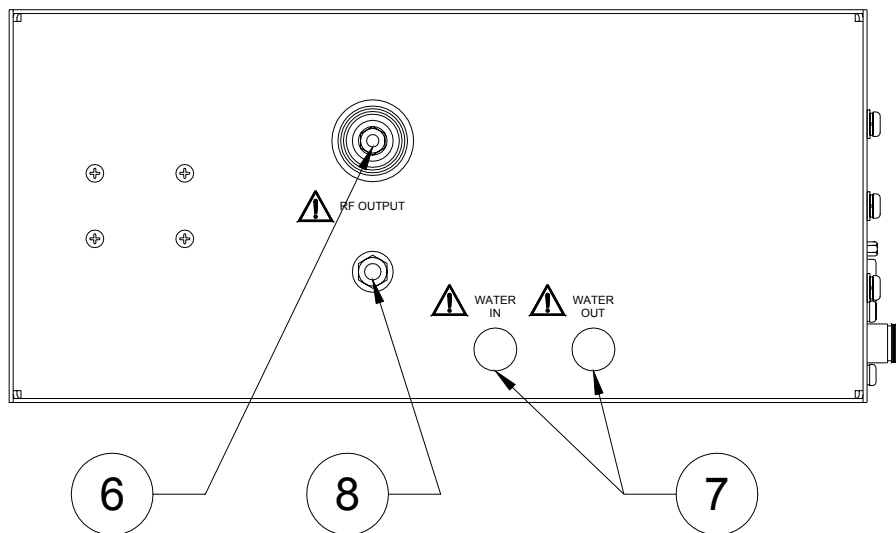

EJAT10 Rear Panel, With Stud Terminal Output

Item	Description
6	RF Output Connector, (2) Type “C” female (generic unit) or 1 Insulated Stud Terminal (10-32 thread) (other output configurations available – consult the factory for details and ordering information)
7	Coolant Water Connection – Not Used on EJAT10 Generic configuration – caps are installed in water fitting holes.
8	RF Return/Equipotential Bonding Terminal

1. RF Input Connector

Coaxial type “N” female. Center pin is RF ‘Hot’, internally connected to the load capacitor and the series inductor. The threaded shell is RF Return, connected to the EJAT10 chassis.

2. Magnitude Error Sensor Null Adjustment Potentiometer

Used to align the EJAT10 Automatic Matching Network during system set-up. Associated with controlling the operation of the Load (shunt) capacitor in automatic operating mode.

3. Phase Error Sensor Null Adjustment Potentiometer

Used to align the EJAT10 Automatic Matching Network during system set-up. Associated with controlling the operation of the Tune (series) capacitor in automatic operating mode.

4. Control Connector

Connector type: 15 pin female D-Sub. Connect to the KJLC EJMC2 Automatic Matching Network Controller's “Matching Network” connector with a shielded cable (purchased separately).

Pin	Signal	Description
1	TUNEMOTOR	Drive voltage input for tune capacitor motor -15VDC to +15VDC
2	GROUND	Return for load capacitor motor. Internally connected to chassis ground.
3	TUNEPOS	Tune capacitor position feedback output. Analog signal, 0.00VDC = minimum capacitance, 5.00VDC = maximum capacitance.
4	+5.25VREF	+5.25VDC reference voltage input for capacitor feedback signals. Do not connect external equipment to this pin.
5	-0.25VREF	-0.25VDC reference voltage input for capacitor feedback signals. Do not connect external equipment to this pin.
6	+12V	+12VDC input for operation of control circuits within the matching network. Do not connect other equipment to this pin.
7	PHASE	Phase (tune) error signal output. Analog output, -10VDC to +10VDC range.
8	MAG	Magnitude (load) error signal output. Analog output, -10VDC to +10VDC range

<b>EJAT10 AUTOMATIC MATCHING NETWORK OPERATOR'S MANUAL</b>
--

9	LOADMOTOR	Drive voltage input for load capacitor motor -15VDC to +15VDC
10	GROUND	Return for tune capacitor motor. Internally connected to chassis ground.
11	LOADPOS	Load capacitor position feedback output. Analog signal, 0.00VDC = minimum capacitance, 5.00VDC = maximum capacitance.
12	GROUND	Internally connected to chassis ground.
13	DC-PROBE	DC Probe signal output. Analog, -10VDC to +10VDC range
14	RF-PROBE	DC Probe signal output. Analog, -10VDC to +10VDC range
15	GROUND	Internally connected to chassis ground.

#### 6. RF Output Connection

Two (2) coaxial connectors, Type “C” female:

Center pin is “RF” hot, internally connected to the Tune (series) capacitor. The connector shell is RF Return, connected to the EJAT10 chassis.

Stud Terminal:

High-voltage insulated threaded stud, thread type is 10-32. Internally connected to the Tune (series) capacitor. RF Return is the Equipotential Bonding terminal (item 8)

Note: Other output connection options are available – consult the factory for configuration details and ordering information.

#### 7. Coolant Water Connection

Not used on Generic EJAT10 configurations. Caps are installed in the water fitting holes

#### 8. RF Return/Equipotential Bonding Terminal

¼-20 x 1” long stud, supplied with 2 washers and a hex nut. Directly connected to the EJAT10 matching network’s chassis. Connect to the plasma chamber or processing apparatus frame ground or system frame ground and the RF Generator’s Equipotential bonding terminal or chassis with a 2” or wider piece of silver-plated copper strap. Keep strap connections as short as possible. Used to minimize RF circulating currents within a processing system.

**UNPACKING:**

Remove the EJAT10 Matching Network for its carton and packing materials. Examine the unit for physical damage. If physical damage is evident, notify both the carrier and KJLC Contact the KJLC service department or a KJLC service representative for assistance.

**INSTALLATION:**

Recommended Accessories (purchased separately)

Consult with your local KJLC sales or service representative to obtain accessory items appropriate for your application and matching network configuration.

Item	Description	KJLC Part Number
EJMC2	Automatic Matching Network Controller	EJMC2
EJAT-Series Control Cable	15 Conductor Shielded, 12-Foot (3.66m) Length, DB-15 Male to DB-15 Male (other lengths available)	EJCB12MC2AT3
RF Input Cable	Coaxial, Type RG-213, Type "N" Male to Type "N" Male, 12-Foot (3.66m) Length	EJCBL12NN

Physical Mounting of the EJAT10 Matching Network

Mount the EJAT10 Matching Network on the plasma chamber or processing apparatus or as close as possible to the plasma chamber or processing apparatus. Ensure vent holes are not blocked or obstructed. Ensure there is a proper RF ground connection between the plasma chamber or processing apparatus and the matching network. If the matching network is not physically mounted to the plasma chamber or processing apparatus, an equipotential bonding (GROUND) strap must be installed.

Grounding (equipotential bonding) of the EJAT10 Matching Network

A solid electrical bond between the matching network's chassis and the plasma chamber or processing apparatus chassis is essential for proper operation and safety. A poor bond may result in erratic matching network performance and an electrical shock or RF burn hazard



**IF THE EJAT10 MATCHING NETWORK CHASSIS IS NOT DIRECTLY BOLTED/ELECTRICALLY BONDED TO THE PLASMA CHAMBER OR PROCESSING APPARATUS, AN EQUIPOTENTIAL BONDING (GROUND) STRAP IS REQUIRED.**

Equipotential bonding straps can be constructed of 0.031" thick by 2" (or wider) Copper strap, preferably silver-plated to enhance conductivity and prevent the copper from oxidizing (tarnished copper is not a good RF conductor). Connect the bonding strap from the EJAT10 Matching Network's rear panel equipotential bonding terminal or chassis to the plasma chamber or processing apparatus chassis.

Bonding straps should be short in length and as wide as possible. Due to operation at 13.56 MHz, the majority of the RF current flows on the surface of the bonding strap (Skin Effect). The more surface area, the better the RF bonding connection. If a single bonding (ground) point is not available, a star-bonding (ground) configuration is recommended.

**Do not daisy chain bonding connections.**

### **Important Note For Water-Cooled Matching Networks:**

Proper water resistivity is crucial for heat extraction and system performance. If the system water resistivity is too low, the water may conduct RF energy from the reactor to ground. This RF energy "leak" is an additional load to the RF delivery system and makes the matching network appear less efficient, resulting in an apparent power loss and is nominally identified by Low DC Developed Bias Voltage. Recommended minimum water Specific Resistivity is 500,000 Ohms per centimeter at 25°C.

### **Connecting the EJAT10 Matching Network Output**

Connect the two (2) rear panel RF Output RF connectors to the plasma chamber or processing apparatus, via two identical length coaxial cables. Keep the length of the coaxial cables as short as possible (under 3 feet).

The plasma chamber or processing apparatus can present low-impedance, high current and/or high impedance, high voltage loads to the EJAT10 Matching network output. RG-393/U or RG-225/U coaxial output cable is recommended for its high-voltage and high temperature properties. Depending on your application, non-Teflon dielectric coaxial cable types may melt or internally arc.

The EJAT10 Matching network utilizes a pair of type "C" connectors for RF output. By using two output connections in parallel, the RF output current is divided, reducing heating of the connection(s) to the plasma reactor.

### **Connecting the EJAT10 Matching Network RF Input**

Connect the matching network's RF Input connector to the RF power source's (RF Generator) RF output connector with a suitable coaxial cable. Coaxial cable types RG-213/U, RG-218/U, RG-393/U, or RG-225/U are recommended.

The RF input cable is, electrically, a component of the matching network. The RF input cable length can affect the matching network's performance and ability to tune. A 12-foot (3.66m or  $\frac{1}{4}$  wavelength at the operating frequency) cable length @ 13.56 MHz is recommended for initial system set-up, and is often sufficient for most applications. Optimum cable length for your application must be empirically determined.

#### Connecting the EJAT10 Matching Network to the EJMC2 Controller

Install the EJMC2 Matching Network Controller into the system rack or convenient system panel. Connect the EJAT-Series Control Cable (DB15M/DB15M) from the matching network's "CONTROL" connector to the EJMC2 Controller's rear panel "MATCHING NETWORK" connector.

Refer to the EJMC2 Matching Network Controller operator manual for installation and operational details.

Ensure the EJMC2 Matching Network Controller is properly configured for your AC Mains Voltage. The AC Mains power inlet on the rear panel of the EJMC2 Controller has a voltage selection indicator and will indicate either "110" or "220". The EJMC2 will operate between 98-125 VAC with 110 indicated and between 198-250 VAC with 220 VAC indicated.

If you are unsure of your AC Mains voltage, consult an electrician before connecting the EJMC2 controller to the AC Mains supply.

Insert the AC Mains power cord into the EJMC2 Controller's power inlet and connect to the AC Mains.

## OPERATIONAL CHECKS

Refer to the EJMC2 Matching Network Controller operator's manual and RF Generator operator's manual for operational details.

### EJAT10 Matching Network "Cold" Check

1. Enable the EJMC2 controller's AC Mains power.
2. Select manual operation of the Load capacitor and depress the Load capacitor MIN button until the Load capacitor reaches its lower limit of travel. The motor should have turned smoothly and an indication of "LOAD MIN" should be displayed on the EJMC2 Controller's front panel.
3. Depress the Load MAX button until the Load capacitor reaches its upper limit of travel. The motor should have turned smoothly and an indication of "LOAD MAX" should be displayed on the EJMC2 Controller's front panel.
4. Return the Load capacitor to the mid-range (50%) position.
5. Select manual operation of the Tune capacitor and depress the Tune capacitor MIN button until the Tune capacitor reaches its lower limit of travel. The motor should have turned smoothly and an indication of "TUNE MIN" should be displayed on the EJMC2 Controller's front panel.
6. Depress the Tune MAX button until the Tune capacitor reaches its upper limit of travel. The motor should have turned smoothly and an indication of "TUNE MAX" should be displayed on the EJMC2 Controller's front panel.
7. Return the Tune capacitor to the mid-range (50%) position.
8. Enable automatic operation for the Load and Tune capacitors

### EJAT10 Matching Network "RF" Check



1. Enable the RF Generator's AC Mains power.
2. Set the RF Generator's power setpoint to 500 Watts and enable the RF output.
3. The plasma should ignite and the reflected power should be minimum. Note the strike and tune position of the load and tune capacitors.
4. Repeat steps 2 and 3 for all processes.

**Should adjustments be required to optimize the EJAT10 Matching Network to your plasma reactor or process, refer to "Range Configuration" in the Problem Solving section.**

**If you can manually position the EJAT10 Matching network's capacitors for minimum reflected power but cannot obtain minimum reflected power in "AUTO" (automatic) mode, refer to "Phase and Magnitude Sensor Adjustment Procedure" in the Problem Solving section.**



**TECHNICAL DATA****Ratings and Specifications**

RF Input Power	1000 Watts Nominal, application dependant
Frequency	13.56 MHz
Connections:	RF Input: Type "N" female RF Output: Two (2) Type "C" female connectors or a Single 10-32 Insulated Stud (other output configurations available – consult the factory for details and ordering information) Control: 15 pin Female D-Sub Type Equipotential Bonding Terminal: ¼-20 x 1" Stud (stud terminal output configurations)
Environmental:	Operating Ambient: 10°C to 40°C Humidity: 80% maximum, non-condensing
Cooling:	Medium: Convection
Matching Elements: (Custom configurations available)	Generic Application Configuration Load Capacitor Range (Variable): 7-1000pF Fixed Loading Capacitors: 200pF x 4 Tune Capacitor Range (Variable): 12-500pF RF Coil: 3 Turns, 3"ID, ¼"O.D. Tubing
Voltage Probe:	DC Voltage, 200:1 Attenuation (Standard), Positive (+) Polarity
Package Dimensions: Inch (mm)	13.38 L x 13.12 W x 6.00 H (339.7 L x 333.2 W x 152.4 H)
Weight	20.0 Lbs. (9.06 Kg)

## **Theory of Operation**

The function of the EJAT10 Automatic Matching Network is to automatically transform the plasma impedance from a mismatched condition to 50 Ohms regardless of load variations. This is accomplished by the using passive components with high voltage and current ratings, configured in a basic type "L" configuration.

### **Loading and Plasma Impedance:**

The shunt or Load elements are connected from the RF input to chassis ground. The loading component is used to drive the plasma impedance to 50 ohms and is accomplished through the use of a variable capacitor with additional fixed capacitors in parallel.

### **Tuning and Plasma Reactance:**

The series or Tune elements work together to counteract the reactive component of the plasma impedance. KJLC EJAT-Series matching networks utilize a fixed inductor in series with a vacuum variable capacitor to counteract the plasma reactance.

### **Phase and Magnitude Sensors:**

These sensors are located on the input of the EJAT10 Automatic Matching Network. The Phase sensor is associated with the operation of the Tune capacitor; the Magnitude sensor is associated with the operation of the Load capacitor. Together, they sense the voltage and current on an internal RF transmission line and generate a direct current (DC) steering signal to drive the servo amplifiers in the EJMC2 Matching Network Controller. The sensor outputs are driven positive or negative depending upon the relationship of the voltage and current through the transmission line.

During initial factory set-up, the tune and load capacitors are manually positioned until the plasma reactance has been transformed to 50 ohms (0 Watts of reflected power – a “matched” condition). The sensor outputs are then nulled (adjusted to 0VDC at a “matched” condition) and automatic operation is verified.

### **DC Voltage Probe:**

A 200:1 DC Voltage probe is included within the EJAT10 Matching Network. The probe provides a means to measure the developed DC Voltage within the plasma chamber. The DC Voltage probe's output signal is proportional to the developed DC within the plasma chamber.

The DC Voltage probe's output can be used by the processing system to monitor plasma chamber or processing apparatus status and/or used as a power regulation feedback signal for the RF generator. Using the DC Voltage probe output for a power regulation feedback signal is commonly referred to as DC Voltage Control. KJLC RF Generators can operate in DC Voltage control mode.

The DC Voltage developed within the chamber has a negative polarity. For compatibility and ease of interfacing, the DC Voltage probe buffer amplifier, located on the Phase and Magnitude circuit board, can be configured to invert the negative polarity DC Voltage signal to a positive polarity DC Voltage signal.

The EJAT-Series Control Cable connects the DC Voltage probe signal to the EJMC2 Controller. The EJMC2 Controller can route the DC Voltage probe signal to the RF Generator for DC Voltage Control operation, to the user's system for monitoring, and display the DC Voltage on its front panel. Refer to the EJMC2 Matching Network Controller for connection and interfacing details.

**Chassis Schematic:**

The Standard Configuration Chassis Schematic for the EJAT10 Matching Network configuration is show below. Other configurations are possible, on a custom-order basis. Contact the KJLC factory or a KJLC service representative for information regarding other application configurations.

**GENERIC APPLICATION**

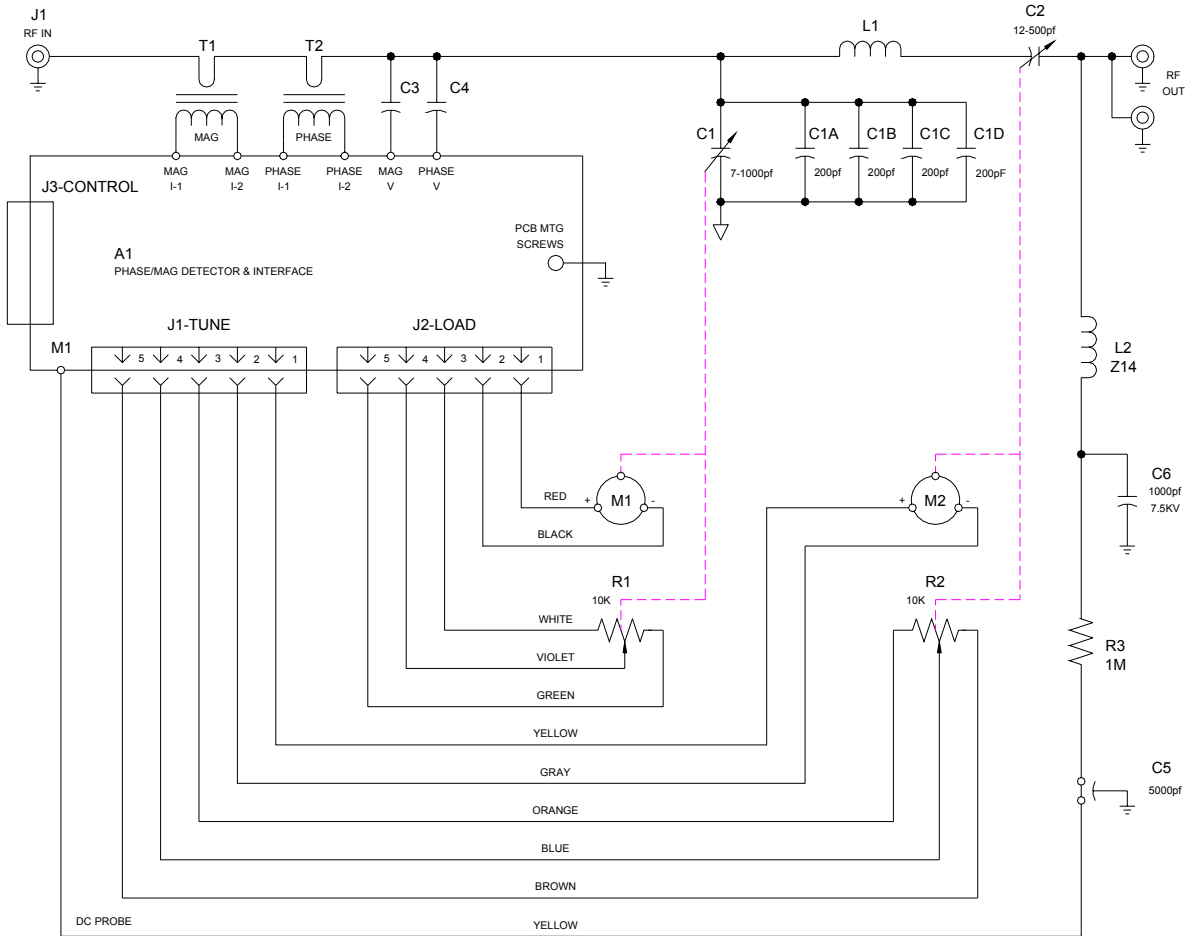

**EJAT10 Chassis Schematic, Generic Application**

Variable and fixed Capacitors value may vary with EJAT10 Configuration and Application.

**Typical System Configuration**

A typical basic system configuration is shown below. The basic configuration consists of the EJMC2 Controller, an EJAT-Series matching network, an RF Power source (generator), and a load. There are no control connections between the EJMC2 controller and the RF Power source and load/processing system. In this configuration, the EJMC2 and matching network operate independently from the RF power source and load/processing system.

Other configurations and wiring schemes are possible. Refer to the EJMC2 Matching Network Controller Operator's Manual for system control connection information. For assistance with system wiring schemes, contact the customer service department or a KJLC service depot. Coaxial cables, control cables, RF generators, and system equipment are not supplied with the EJAT10 Matching Network.

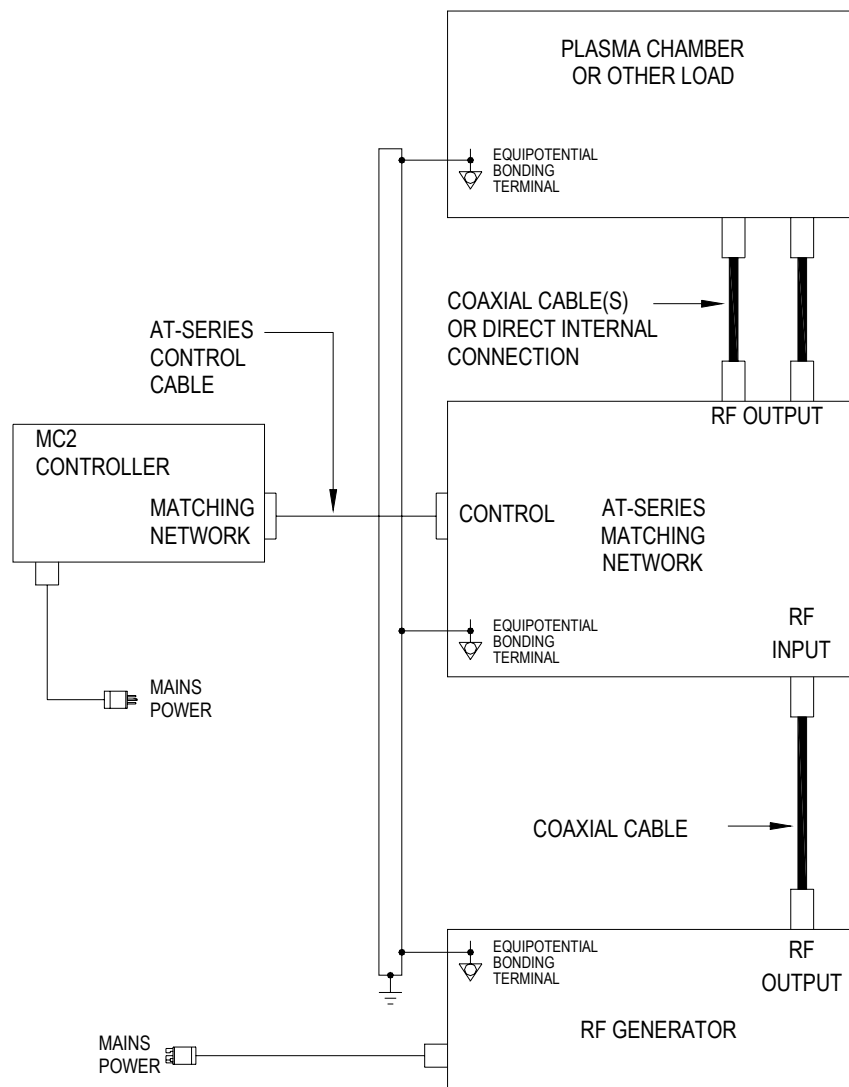

Typical System Configuration

**CONTROL INTERFACE CONNECTION**

The wiring diagram below shows the EJAT10 to EJMC2 Controller control interface connections. The EJAT-Series Control Cable, an accessory item, makes the connections shown below and is available for purchase. Use 24 AWG or larger cable for matching network to controller connections. For cable runs greater than 24 feet in length, 22 AWG cable is recommended

For information on interfacing the EJMC2 Controller to the RF Generator or processing system, refer to the EJMC2 Controller's Operator Manual, KJLC Document number 6200070000. All EJAT-Series Matching networks use the same control interface wiring.

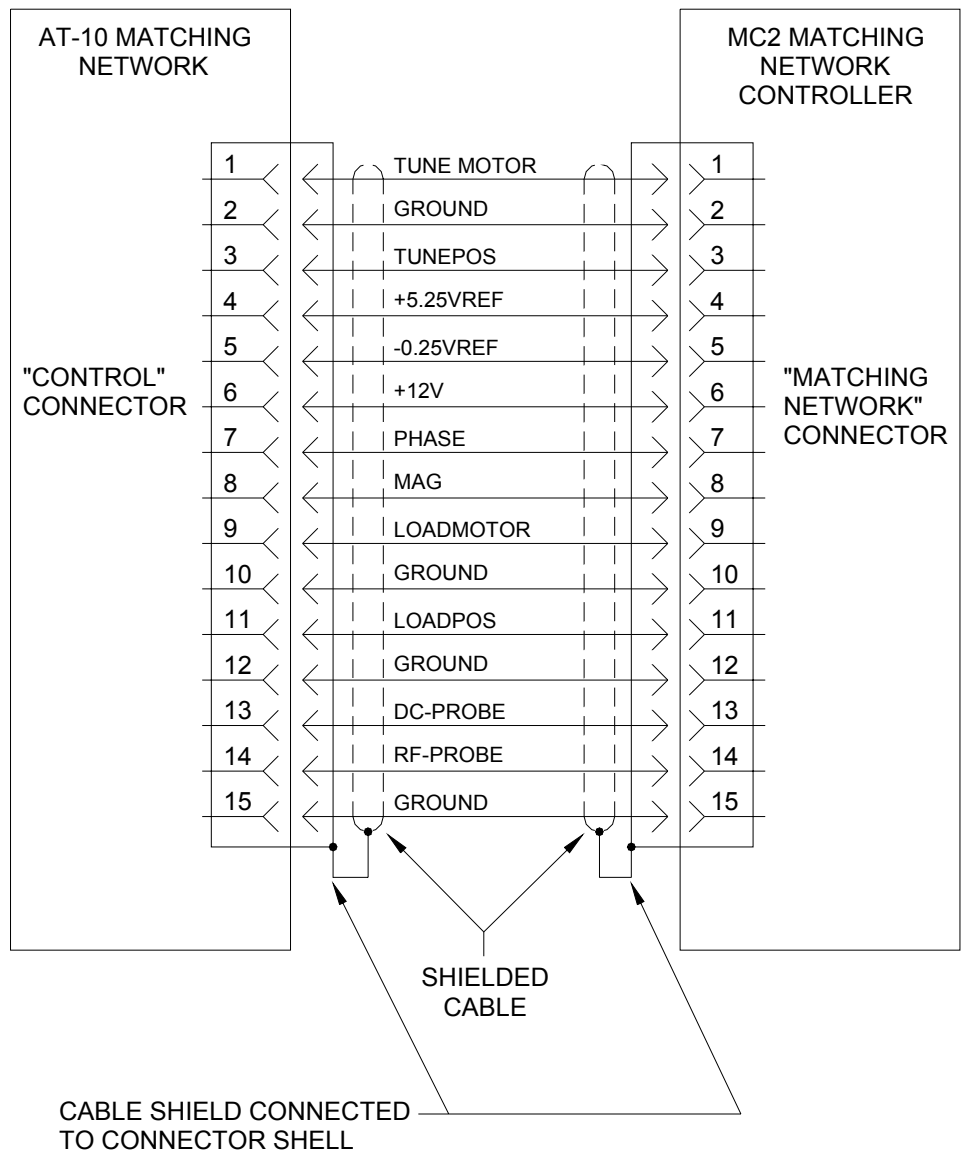

EJAT10 Control Interface Connections

**MAINTAINENCE:**

The EJAT10 Automatic Matching Network is designed to be maintenance free. There are no user maintainable assemblies inside the unit. The EJAT10 is designed for use in a clean environment. Periodically check air vents for accumulation of dust and debris. Clean the air inlets with a vacuum cleaner if they appear dirty or clogged.



Restricting the air vents or installing the EJAT10 Automatic Matching Network in a dusty environment may impact the long-term reliability of the matching network. Severe dust contamination can accumulate across high-voltage points cause internal arcing.

Cleaning:

**DO NOT** clean the EJAT10 Automatic Matching Network when RF power is applied to the matching network. The exterior of the matching network may be cleaned with a soft cloth, dampened with soap and water or a mild solvent, such as alcohol.

## **PROBLEM SOLVING**

### *Problem Solving Chart*

The following chart lists some conditions that may occur and the recommended solutions. Follow the suggested solutions until the problem is corrected. If the problem persists, please contact KJLC customer service or a KJLC service representative.

<b>Condition</b>	<b>Suggested Solution</b>
The matching network motors do not turn	<p>Verify the EJAT-Series Control cable is properly mated to the Matching network's "CONTROL" connector.</p> <p>Verify the EJAT-Series Control cable is properly mated to the EJMC2 Controller's "MATCHING NETWORK" connector.</p> <p>Make sure the EJMC2 controller's power switch is in the "ON" position and the power cord is properly mated to the rear panel inlet.</p> <p>Make sure AC Mains power is applied to the EJMC2 Controller</p>
The matching network does not tune when RF Power is applied to the matching network	Check the EJMC2 controller's load and tune capacitor's mode settings. Ensure both the Load and Tune capacitors are set to the "AUTO" (automatic) mode
The top line of the EJMC2 Controller displays "LOAD 0% TUNE 0%" (EJMC2 software version 9E or later)	<p>Verify the EJAT-Series Control cable is properly mated to the Matching Network's "CONTROL" connector.</p> <p>Verify the EJAT-Series Control cable is properly mated to the EJMC2 Controller's "MATCHING NETWORK" connector.</p> <p>The capacitor feedback signal from both capacitors may have failed. Contact the nearest KJLC service representative or factory service department for assistance.</p>
The top line of the EJMC2 Controller displays "CABL FAIL CABL FAIL" (EJMC2 software version 9D or earlier)	<p>Verify the EJAT-Series Control cable is properly mated to the Matching Network's "CONTROL" connector.</p> <p>Verify the EJAT-Series Control cable is properly mated to the EJMC2 Controller's "MATCHING NETWORK" connector.</p> <p>The capacitor feedback signal from both capacitors may have failed. Contact the nearest KJLC service representative or factory service department for assistance.</p>
The top line of the EJMC2 Controller displays	One of the internal capacitor position feedback signals may have failed. Contact the nearest KJLC service



**EJAT10 AUTOMATIC MATCHING NETWORK OPERATOR'S MANUAL**

<b>Condition</b>	<b>Suggested Solution</b>
<p>"LOAD 0% TUNE XX%" or "LOAD XX% TUNE 0%" (EJMC2 software version 9E or later)</p>	<p>representative or factory service department for assistance</p>
<p>The top line of the EJMC2 Controller displays "CABL FAIL TUNE XX%" or "LOAD XX% CABL FAIL" (EJMC2 software version 9D or earlier)</p>	<p>One of the internal capacitor position feedback signals may have failed. Contact the nearest KJLC service representative or factory service department for assistance</p>
<p>The Load and/or Tune capacitor travels to a limit and "chatters" or "oscillates" in automatic mode when RF power is applied</p>	<p>The "chatter" is caused by the capacitor(s) being driven to the end-of-travel limit by the automatic mode and the "BACKOUT" feature is pushing the capacitor away from the end-of-travel limit.</p> <p>Temporarily switch to "MAN" (manual) mode to confirm – the "chatter" should stop.</p> <p>The matching network's range configuration may need adjustment. See the "Range Configuration" heading in the Problem Solving section</p>
<p>"LOAD MAX" is displayed on the front panel during automatic operation.</p>	<p>The matching network's range configuration may need adjustment. See the "Range Configuration" heading in the Problem Solving section</p>
<p>"LOAD MIN" is displayed on the front panel during automatic operation.</p>	<p>The matching network's range configuration may need adjustment. See the "Range Configuration" heading in the Problem Solving section</p>
<p>"TUNE MAX" is displayed on the front panel during automatic operation.</p>	<p>The matching network's range configuration may need adjustment. See the "Range Configuration" heading in the Problem Solving section</p>
<p>"LOAD MIN" is displayed on the front panel during automatic operation.</p>	<p>The matching network's range configuration may need adjustment. See the "Range Configuration" heading in the Problem Solving section</p>
<p>The matching network tunes automatically, but reflected power is not Zero (0) Watts. Reflected power is less than 10 Watts and can be tuned to Zero (0) Watts in manual mode.</p>	<p>On some systems, a perfect (0W reflected power) may not be possible or a slight mis-match (1W to 5W of reflected power) may be considered tolerable due to process variations or a multi-process system configuration.</p> <p>If needed, the Phase and Magnitude sensor may be adjusted. Refer to the "Phase And Magnitude Sensor Adjustment Procedure" heading in the Problem Solving section.</p>

EJAT10 AUTOMATIC MATCHING NETWORK OPERATOR'S MANUAL

<b>Condition</b>	<b>Suggested Solution</b>
The matching network tunes automatically, but reflected power is not Zero (0) Watts. Reflected power is greater than 10 Watts and can be tuned to Zero (0) Watts in manual mode.	The Phase and Magnitude sensor may require adjustment. Refer to the "Phase And Magnitude Sensor Adjustment Procedure" heading in the Problem Solving section.

Range Configuration

Unless otherwise specified at the time of order, the EJAT10 Automatic Matching network is shipped with a “generic” range configuration. On some systems, the generic range configuration may be insufficient to obtain a matched (0 Watts Reflected power) condition. Refer to the chart below to adjust the matching network's range.

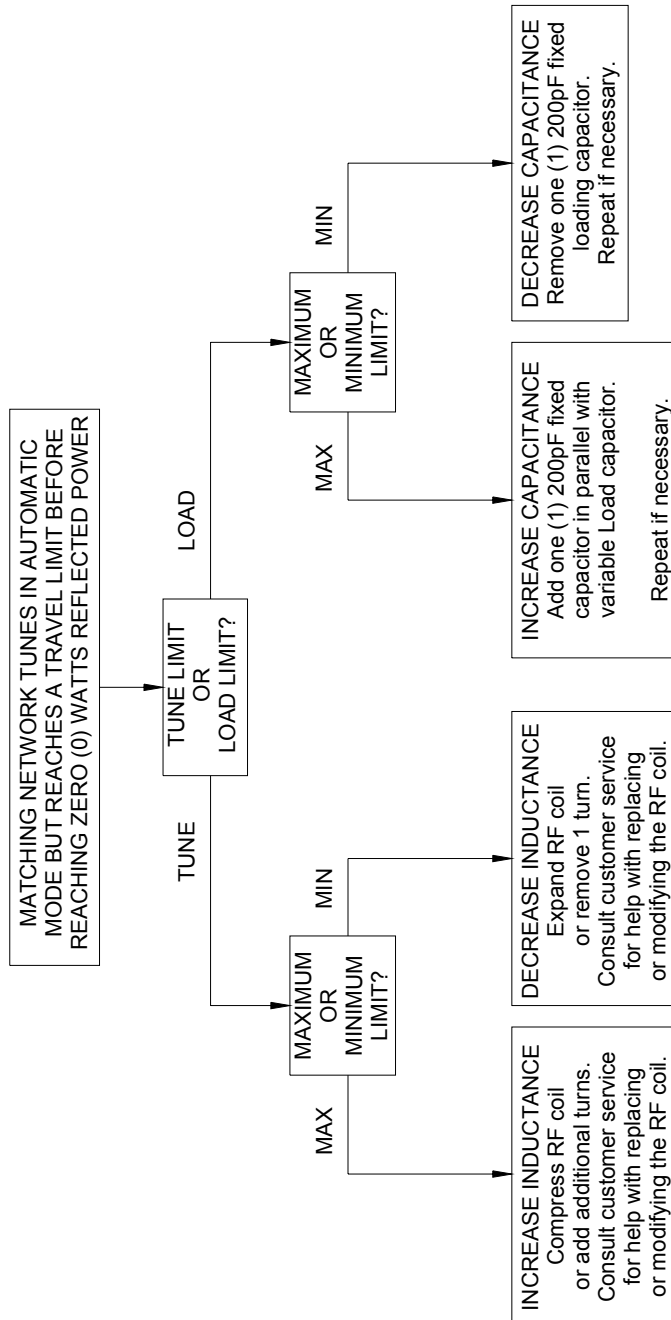

Phase and Magnitude Sensor Adjustment Procedure:

If your EJAT10 Matching Network can optimally match to your plasma chamber or processing apparatus in manual mode, but not in automatic mode, or your matching network's hardware configuration required changes to meet your process requirements, adjustment of the Phase and Magnitude error sensor may have to be performed. Use the following procedure to adjust the Phase and Magnitude Error Sensor.

Required test equipment: Digital Multimeter, Fluke Model 77 Type III or equivalent (KJLC recommends the Fluke digital multimeter because of its superior immunity to RF Interference)

1. At the EJMC2 Controller, set the Load and Tune capacitor modes to "MAN" (manual)
1. Set the RF Generator's power setpoint to 500 Watts and enable the RF output.
2. Manually adjust the matching network's Load and Tune capacitors for minimum reflected power at the RF Generator.
3. Insert the negative (-) multimeter test lead into the "COM" test point on the rear panel of the EJMC2 Controller.
4. Insert the positive (+) multimeter test lead into the "PHASE" test point on the rear panel of the EJMC2 Controller.
5. Adjust the "PHASE" potentiometer, located on the left side panel of the EJAT10 Matching Network for a 0.000VDC +/- 0.005VDC reading on the multimeter.
6. Remove the positive (+) multimeter test lead from the EJMC2 Controller's rear panel "PHASE" test point.
7. Insert the positive (+) multimeter test lead into the "MAG" test point on the rear panel of the EJMC2 Controller.
8. Adjust the "MAG" potentiometer, located on the left side panel of the EJAT10 Matching Network for a 0.000VDC +/- 0.005VDC reading on the multimeter.
9. Set the EJMC2 Controller Load and Tune capacitor modes to "AUTO" (automatic) and confirm the matching network tunes to zero (0) Watts reflected.
10. Increase the RF Generator's output power to 2000 Watts (or maximum power if less than 2000 Watts).
11. Repeat steps 2 through 9.
12. Disconnect the multimeter from the EJMC2 Controller's rear panel test points.
13. Disable the RF generator's RF output.
14. End Of Procedure

EJAT10 AUTOMATIC MATCHING NETWORK OPERATOR'S MANUAL
---

**RELATED DOCUMENTS:**

<b>Title</b>	<b>KJLC Part Number</b>
EJMC2 Matching Network Controller Operator's Manual	EJMC2

**REVISION HISTORY:**

<b>Revision</b>	<b>Date</b>	<b>Revision Description</b>
0.90	3/28/03	Preliminary
1.00	9/17/03	Issued
1.01	9/28/03	Referenced EJMC2 Controller Software Versions 9D and 9E in problem solving section.

## **KJLC 1 Year Limited Warranty**

KJLC products are warranted to the original purchaser against defects in material and workmanship for a period of one year from the date of delivery.

KJLC will repair or replace, at its option, all defective products returned freight prepaid during the warranty period, without charge, provided that there is no evidence the product has been mishandled, abused, or misapplied. Our liability under this warranty is limited to servicing, repairing, or replacing any defective products for a period of one year after delivery to the original purchaser.

If warranty service is required, the equipment must be returned, transportation charges prepaid, to our factory or authorized service depot. In the case of misuse, abnormal operating conditions, or other non-warranty work, a repair cost estimate will be submitted for approval before work is started.

### WHAT THE WARRANTY DOES NOT COVER:

This warranty covers only defects in materials and workmanship provided by KJLC and does not cover equipment damage or malfunction from misuse, abuse, accident, act of God, non-KJLC modification or upgrade. Improper return shipping, packaging, or shipping damage is not covered. KJLC will not be liable for any incidental or consequential damages resulting from your use of, or inability to use your Matching Network.

### IF YOU HAVE A PROBLEM

The first step is to contact your system vendor. Consult with your system vendor to determine the nature of the problem. Your system vendor knows the intimate details of how your processing system interfaces and operates with the EJAT10 Automatic Matching Network and EJMC2 Matching Network Controller and can efficiently resolve system related problems.

If it is determined that the Matching Network or Controller has a problem, contact the nearest KJLC service representative or our customer service department at 1-800-245-1656. Before you call, please be ready to provide the model number of your Matching Network and Controller, its serial number, date of manufacture, a description of the problem, and the model and manufacturer of the processing system it is used on.

### HOW IS WARRANTY SERVICE OBTAINED?

Our customer service representative will explain how to obtain service under this warranty. Please save the original packing materials in order to facilitate shipment.

## Glossary of Terms

A	Amperes, a measurement unit of current
AC	Alternating Current
Chamber	Industry term for a vacuum chamber used in plasma processing equipment.
D-Sub	Industry term for D-Subminiature connector
DC	Direct Current
Equipotential Bond Equipotential Bonding	Equipotential bonding (often referred to as grounding) is used to control RF circulating currents within a system. For regulatory purposes, it is not a "Protective Earth" or "Safety Ground", even though it may be bonded to the "Protective Earth" or "Safety Ground" within the equipment or user's facility.
KHz	Kilo Hertz, a measurement unit of frequency (1000 Hertz)
KVA	Kilo Volt-Amperes
Load Capacitor	Industry term for a shunt capacitor in an "L" type impedance matching network. Can be fixed or variable type.
Matchbox	Industry term for an impedance matching network
MHz	Mega Hertz, a measurement unit of frequency (1,000,000 Hertz)
mV	Milli-Volts, a measurement unit of Voltage, equal to 1/1000 of a Volt.
Non-Volatile Storage	Also know as non-volatile memory. Computer memory that retains its data after power has been removed.
RF Generator	Industry term for Radio Frequency Power Supply
RF	Radio Frequency
Strike Preset	A pre-determined (usually empirically) starting positions for the matching network's capacitors – an aid for plasma ignition.
TTL	Transistor-Transistor Logic
Tune Capacitor	Industry term for the series capacitor in an "L" type impedance matching network. Can be fixed or variable type.
Tuner	Industry term for an impedance matching network
VAC	Volts, Alternating Current
VDC	Volts, Direct Current
W	Watts